



# 2 1/2" BORE ACCESSORIES



## MOUNTING NUTS

### Stud Nut

Part Number	Across Flats	Nut Thickness	Nut (Thread)
<b>N22-12</b>	1 7/8"	1/2"	1 3/8-12

### Rod Nut

Part Number	Across Flats	Nut Thickness	Nut (Thread)
<b>N08-20</b>	3/4"	5/16"	1/2-20

## CB-3295

Clevis Bracket  
Material: steel, bright zinc plated

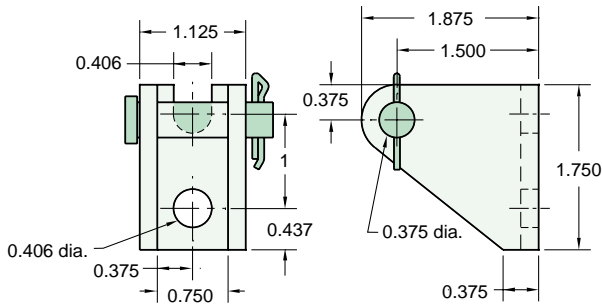

## RK-4099

Replaceable Rod Seal  
Material: aluminum body

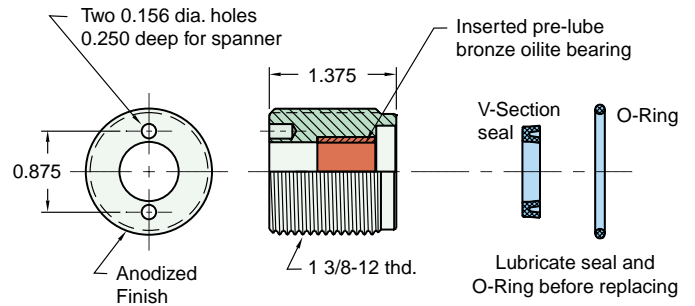

## RC-3281

Rod Clevis  
Material: steel, bright zinc plated

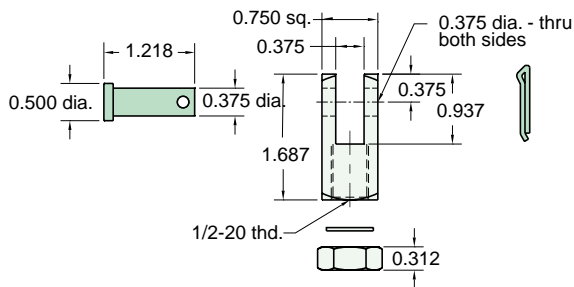

## RE-3285

Rod End  
Material: steel, bright zinc plated body

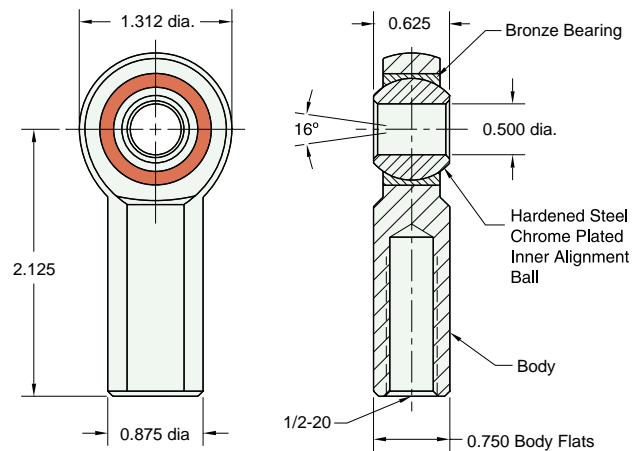

## FB-4091

Foot Bracket  
Material: steel, bright zinc plated

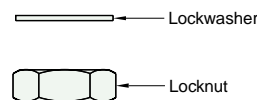
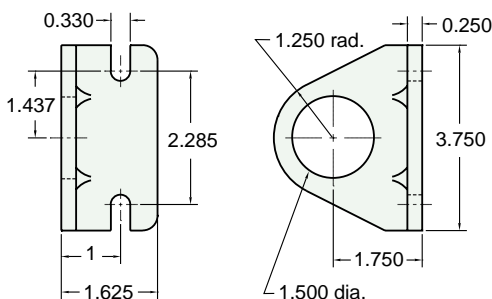

Max. Static Radial Load: 6700 lbs.  
Fits Rod Thread Size: 1/2-20